

SLIMLINE VOGUE® VERTICAL BLIND SYSTEM SIDE DRAW WITH WAND OPERATION

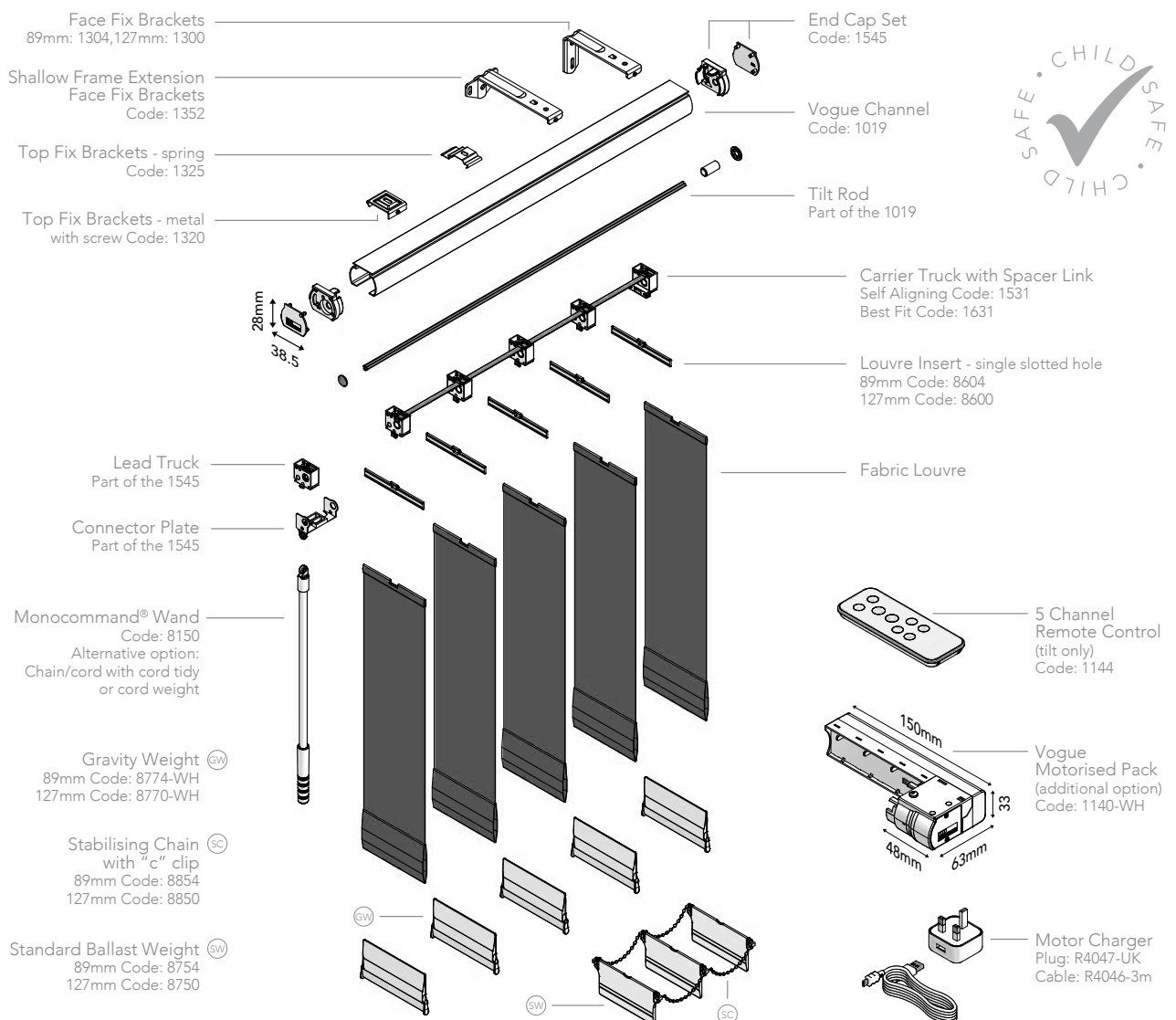

- Designed and manufactured in the UK, and has been 10 year life cycle tested to ensure long lasting performance.
- A robust and reliable, industry leading vertical blind system, made of high quality plastic, stainless steel and aluminium with corrosion resistant finishes.
- Sleek, stylish high performance system available in 6 colours.
- Slimmer end caps for reduced lightstrike and extra privacy.
- UV stabilised prime plastics used to guard against ultraviolet degradation.
- 5m length tracks available for wider windows and doors.
- Side or split draw options.
- Works on friction and not wheels so a low operating noise.
- Self-aligning carrier trucks have limit stops allowing the louvre to rotate to 185° for better closure.
- Unique equidistant linked carriers with stainless steel links for extra durability.
- Chainless Gravity weight now available (89mm: 8774-WH; 127mm: 8770-WH).
- Child safe operating wand option, used in conjunction with a connector plate to distance the wand from the last louvre for neat alignment when the blind is closed.
- Can be motorised (tilt only) using Louvolite One Touch™ Vogue Motorisation (1140-WH)
- Colours available: Channel: white, brown, brushed aluminium, anthracite grey, champagne gold and piano black; End caps: white, grey, brown, black and chrome; Motor: white and black.

HARDWARE SPECIFICATION

Louvolite Slimline Vogue® Vertical Blind System

Vertical Blinds are manufactured using the Louvolite Slimline Vogue® System with aluminium headrail 38.5mm x 28mm and include carrier trucks with UV stabilised self-aligning peg hooks. Operation is with either No 6 size chain in plastic or metal or aluminium Wand.

The brackets used are made from mild steel, zinc plated and powder coated and are suitable for top or face fixing.

The tracks, made from aluminium, prime plastic or stainless steel, are smooth running and robust in design to minimise damage.

The fabric used for the louvre will be creased and punched

so that a UV stabilised hanger - also with a hole - can be stitched or welded into the top of the louvre.

Headrail

The headrail extrusion is made from prime aluminium and is available in white, black, gold, anthracite grey and brown powder coated or brushed aluminium, which makes it corrosion resistant. Brackets are zinc plated or powder coated and manufactured with a strengthening crease for increased strength and safety.

Carrier Trucks

Manufactured using prime quality plastic materials, this ensures a positive and smooth operation while providing durability and protection from

embrittlement and UV rays. UV stabilised louvre hangers are manufactured using Nylon No. 6 plastic.

The gears in the carrier trucks that rotate the louvres are self-aligning with limit stops. This allows louvre rotation to 185°, enabling efficient closure without strain on the mechanism. The spacing between the carrier trucks is controlled by high-grade stainless steel spacer links. The standard spacing is either 77mm for 89mm louvres or 115mm for 127mm louvres, although alternative size options are available for equidistant louvre spacing.

Louvres

All louvres are weighted with interlinked, front and

back with ball and 'C' clip connectors or gravity weight.

Operation

Using manual or motorisation operation, all blinds must be compliant with the child safety elements of BS EN13120. Where children may be present, the chain must be fitted with cord tidy devices.

Maintenance

All of the Slimline Vogue® components are manufactured using aluminium, plastic or stainless steel. They do not present any corrosion problems in normal environments. The system has been designed for smooth operation, together with a rigidity to prolong the window blind's working life.

SLIMLINE VOGUE® BRACKET DIMENSIONS

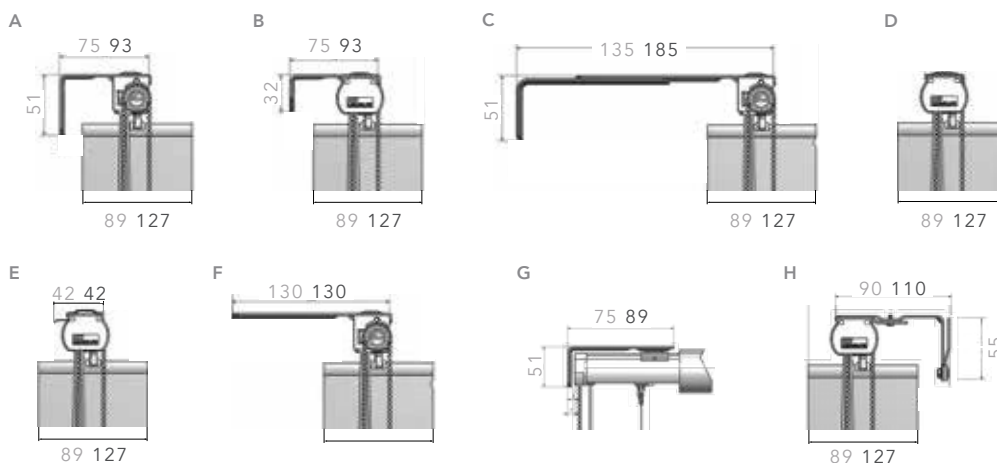

Key: 89mm louvre width
127mm louvre width

- A. Face fix brackets.
1304: 89mm 1300: 127mm
- B. 1352 shallow frame extension face fix brackets
- C. 1340 adjustable face fix brackets
- D. 1320 top fix brackets (screw)
- E. 1325 top fix brackets (spring)
- F. Extension top fix brackets.
1342: 80mm/180mm;
1341: 130mm/230mm;
1351: 160mm/260mm
- G. 1360 side fix brackets
- H. Pelmet brackets

BUNCHING OPTIONS AND STACKING DISTANCES

	ONE WAY	SPLIT	CENTRE
89mm	225mm for 1st metre width of blind. 175mm for each extra metre	225mm for 1st metre width of blind. 175mm for each extra metre	165mm for 1st metre width of blind. 165mm for each extra metre
127mm	190mm for 1st metre width of blind. 115mm for each extra metre	135mm for 1st metre width of blind. 55mm for each extra metre	115mm for 1st metre width of blind. 115mm for each extra metre

For the most up-to-date information view the online pdf at www.louvolitecommercial.com/systems/

Your Louvolite Slimline Vogue® Distributor:



CI/SIB 1976 reference by SIB Agency		
(76.7)	X	