

SYSTEM 40® ROLLER SYSTEM WITH FREE LINK COUPLING BRACKET SET

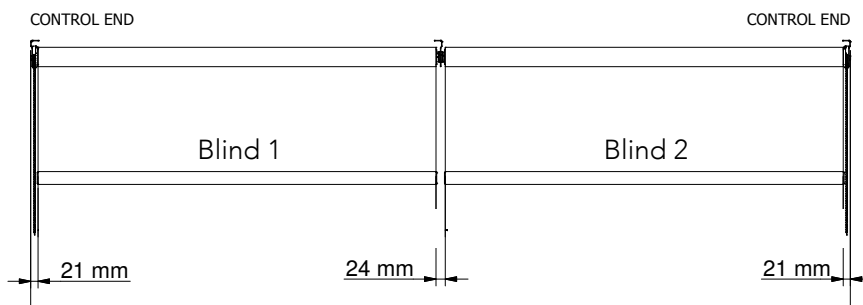
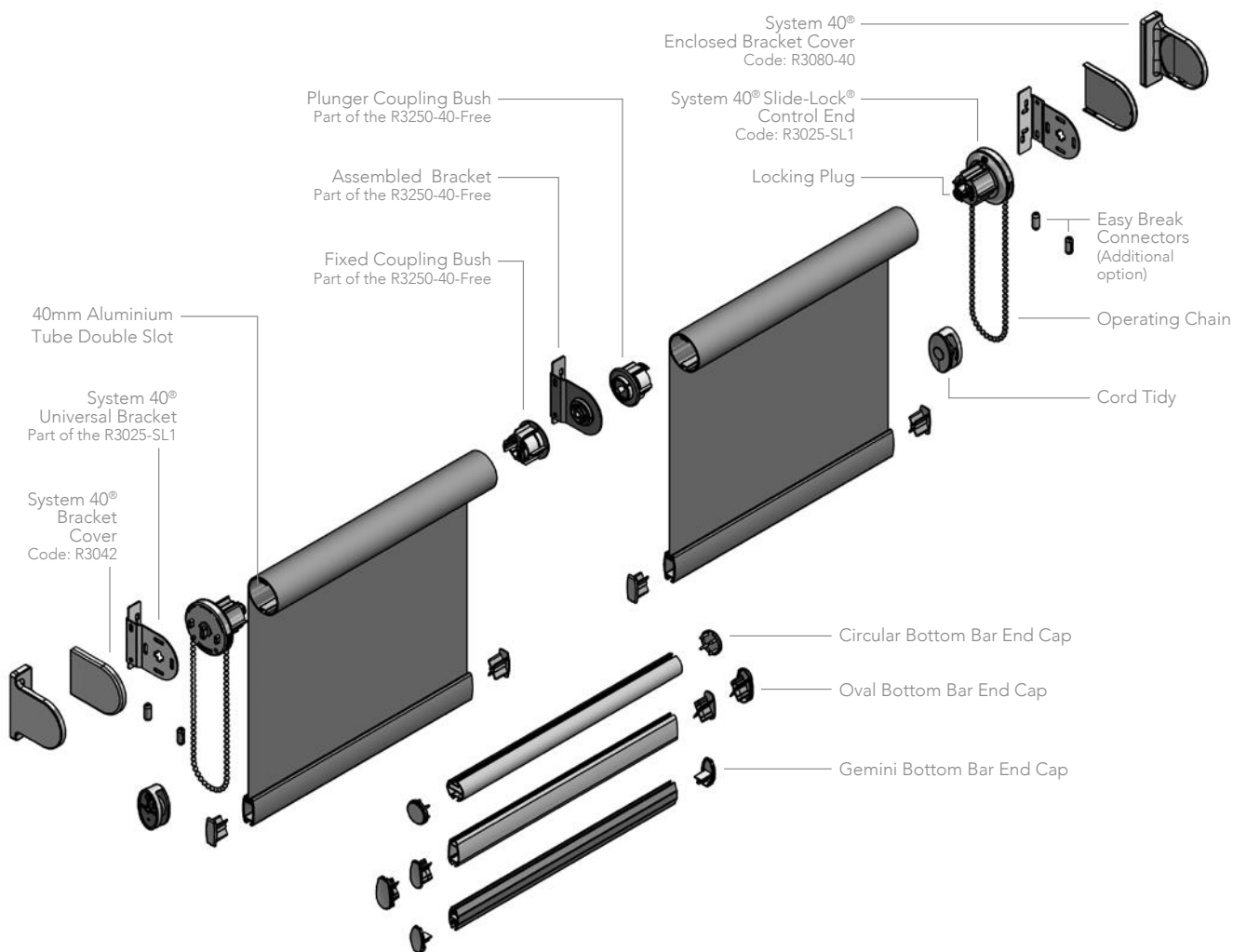

- Designed and manufactured in the UK, all Louvolite systems are 10 year life cycle tested to ensure long lasting performance.
- The System 40® Free Link coupling bracket set joins two sets of blinds together allowing fully independent operation,

whilst sharing a common centre support bracket.

- Useful when covering large areas of glass as openings with different drops can be covered using a shared intermediate bracket.
- For blinds up to 2.5m wide, with

a 9lb maximum holding weight. Achieve widths of up to 3.2m using the 40mm heavy duty tube (R8025-HD).

- Manufactured using high quality engineering grade polymer.
- The coupling bracket system allows blinds to be motorised (Code: R1795-40) using Louvolite One Touch™ Lithium rechargeable motor (R1912, R1912-SHORT, R1918) or hard wired AC motor (R1725).
- Colours available: Back bar bracket set: white, beige, grey and black. Additional cassettes and system bracket sets have their own dedicated colours.

HARDWARE SPECIFICATION

System 40® Roller System

Our roller blinds are manufactured using the Louvolite System 40® roller blind mechanism with specifically designed grooved 40mm aluminium tubing. The specified fabrics are formed and held into the tube with locking tape. The side control units are made from glass filled Nylon 6, with an acetal sprocket and sprocket guard, and includes a locking spring.

The operating chain, No. 10 size in metal or plastic, ensures reliable performance, and improved chain location enables quick and easy on-site adjustment. The mild steel brackets are zinc plated and powder coated, suitable for top, face or side fixing.

A sprung plunger end mechanism is positioned at the opposite end to the control unit, providing a more

secure fit of the blind and smooth operation. The side control unit is fitted with a centre plug that ensures the mechanism operates smoothly even under extreme loads.

Colour spec: White RAL 9010, Black RAL 9011

Performance

To ensure a positive performance, all Louvolite Roller System units are designed and manufactured in the UK using prime quality plastic materials and a dedicated steel locking spring. The sidewinders will lock into the bracket with the unique bracket securing pin for safety after installation.

10 year life cycle testing is done to ensure long lasting performance.

Operation

Using manual or motorised

operation, all blinds must be compliant with the child safety elements of BS EN13120. Where children may be present, the chain must be fitted with easybreak connectors or a cord tidy.

Bottom Bar

Oval, made of aluminium or pvc, can be single or double wrapped in fabric or left exposed, while circular and the dual face Gemini, made of aluminium, only have the fabric formed and locked into the top part to leave the bar exposed. All fabric is formed and held into place with locking tape. The dual face Gemini bar, smooth on one side and angular on the other, improves the ease of manufacture and use of thicker laminate fabrics.

Maintenance

All of the System 40® roller

blind system components are manufactured using aluminium, treated steel and plastic. They do not present any corrosion problems in normal environments. The system has been designed for a smooth operation, together with a rigidity to prolong the window blind's working life. Manufacturing size restrictions are included in this specification brochure.

Additional Options:

Cassettes are specially designed and powder coated with dedicated top fix or face fix brackets. The user has the choice between a single coloured extrusion in various colours or a fascia which incorporates the same fabric or contrasting fabric. Other options not shown are 40mm Back Bar and 75mm (3") Fascia.

ADDITIONAL OPTIONS - CASSETTES

System 32/40® Open Cassette
- 40mm fascia depth. Code: RM2106
white, beige, black, satin, chrome, bronze & anthracite grey

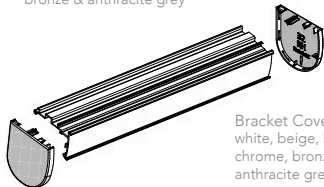

Bracket Covers: RM2134
white, beige, black satin, chrome, bronze, grey & anthracite grey

System 32/40® Full Fascia Cassette
- 70mm fascia depth. Code: RM2108
white, black & anthracite grey

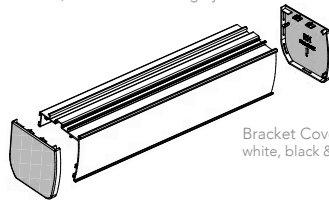

Bracket Covers: RM2138
white, black & anthracite grey



LOUVOLITE SIDE CONTROL SYSTEMS MAXIMUM BLIND SIZE

SYSTEM	FABRIC GROUP	BLIND WIDTH (m) FOR BLIND DROP (m)						40HD	MAX HOLDING WEIGHT
		0.5	1.0	1.5	2.0	2.5	4.0		
System 40®		5.0	5.0	5.0	5.0	5.0		3.0	9lb blind at 6mm deflection
		3.75	3.75	3.75	3.75	3.75		5.0	
		5.0	5.0	5.0	3.55	2.7		3.75 2.1	
System 45®	up to 200g/m sq 200 > 320g/m sq 320 > 485g/m sq	6.0	6.0	6.0	6.0	6.0			12lb blind at 9mm deflection
		4.75	4.75	4.75	4.75	4.75			
		6.0	6.0	6.0	5.0	4.0			
System 55®							4.5 2.80 1.85	24lb blind at 6mm deflection	

System 55® Easi Lift™ is recommended for use on all blinds over 10lbs (4.5kgs) to give optimum performance. Can also be used for 75mm (3") fascia.

For the most up-to-date information view the online pdf at www.louvolitecommercial.com/systems/

Your Louvolite System 40® Free Link Coupling Bracket Distributor:



CI/SIB 1976 reference by SIB Agency		
(76.7)	X	