

SYSTEM 40® ROLLER SYSTEM WITH THE DOUBLE BRACKET

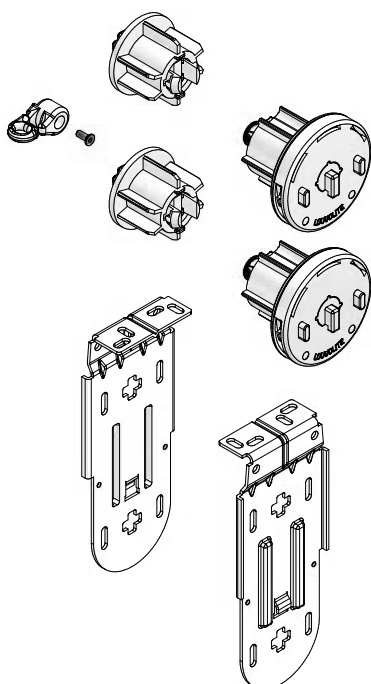
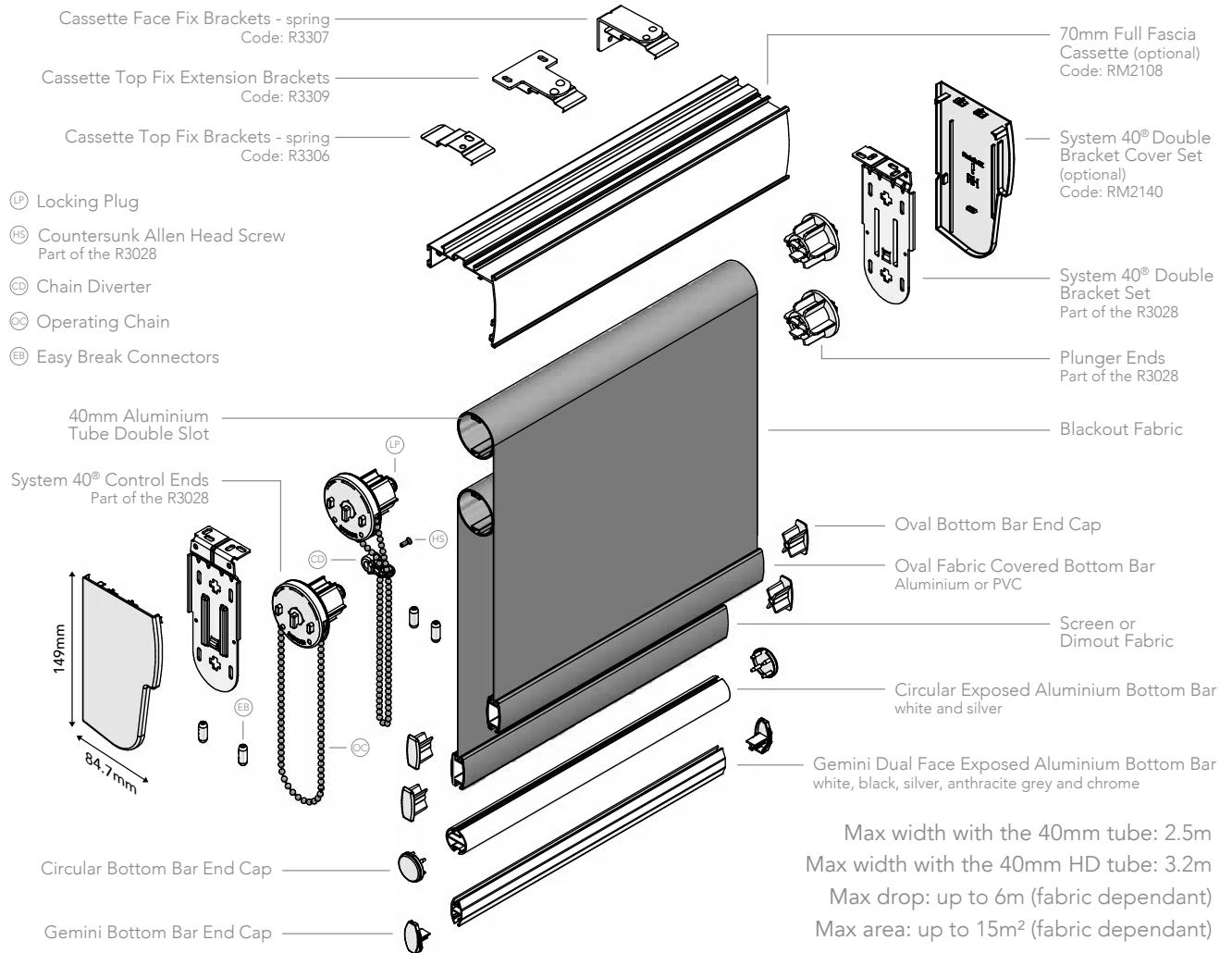

- Designed and manufactured in the UK, all Louvolite systems are 10 year life cycle tested to ensure long lasting performance.
- System 40® Slide-Lock® combines heavier holding weights with anti-fray features that ensure enhanced blind performance.
- For blinds up to 2.5m wide, with a 9lb maximum holding weight. Achieve widths of up to 3.2m using the 40mm heavy duty tube (R8025-HD).
- Improved chain location for quick and easy on-site adjustment.
- Manufactured using high quality engineering grade polymer.
- Universal brackets and a spring idle end plunger enable easy and quick installation.
- Locking plug ensures continued performance of larger blinds.
- Suggested fabric combination is to use blackout fabric as the top blind and screen or dimout fabric as the bottom blind.
- The double bracket system can be motorised (Code: R1795-40) using Louvolite One Touch™ Lithium rechargeable motor (R1912, R1918) or hard wired AC motor (R1725).
- Available in white, black and anthracite grey.

HARDWARE SPECIFICATION

System 40® Double Bracket Roller System

Our roller blinds are manufactured using the Louvolite System 40® roller blind mechanism with specifically designed grooved 40mm aluminium tubing. The fabrics are formed and held into the tubes with locking tape. It is recommended the top fabric be blackout and reverse rolled and the bottom fabric be screen/dimout and standard rolled.

The side control units are made from glass filled Nylon 6, with an acetal sprocket, sprocket guard and locking spring. The operating chain, No. 10 size in metal or plastic, ensures reliable performance, and improved chain location enables quick and easy on-site adjustment. A chain diverter is required when the two controls are on the same side. Mild steel brackets are zinc plated and powder coated, suitable for top, face

or side fixing.

A sprung plunger end mechanism is positioned at the opposite end to the control unit, providing a more secure fit of the blind and smooth operation. The side control unit is fitted with a centre plug that ensures the mechanism operates smoothly even under extreme loads.

Colour spec: White RAL 9010, Black RAL 9011, Anthracite Grey RAL 7016

Performance

10 year life cycle tested to ensure long lasting performance. All Louvolite roller system units are designed and manufactured in the UK using prime quality plastic materials and include a dedicated steel locking spring to ensure a positive performance. The sidewinders lock into the bracket with the unique bracket securing pin for safety after installation.

Operation

Using manual or motorised operation, all blinds must be compliant with the child safety elements of BS EN13120. Where children may be present, the chain must be fitted with easybreak connectors or a cord tidy.

Bottom Bar

Oval, made of aluminium or pvc, can be single or double wrapped in fabric or left exposed, while circular and the dual face Gemini, made of aluminium, only have the fabric formed and locked into the top part to leave the bar exposed. All fabric is formed and held into place with locking tape. The dual face Gemini bar, smooth on one side and angular on the other, improves the ease of manufacture and use of thicker laminate fabrics.

Maintenance

All of the System 40® roller blind system components

are manufactured using aluminium, treated steel and plastic. They do not present any corrosion problems in normal environments. The system has been designed for a smooth operation, together with a rigidity to prolong the window blind's working life. Manufacturing size restrictions are included in this specification brochure.

Double Bracket 70mm Full Fascia Cassette

Roller blinds with cassettes are manufactured as per the standard Louvolite System 40® and include the specially designed powder coated cassette system with dedicated top, direct or face fix brackets. On specification the user has the choice between a single coloured extrusion in dedicated colours or a fascia which incorporates the same fabric or contrasting fabric used on the roller blind.

DOUBLE BRACKET DIMENSIONS

A. 40® double metal bracket top fix

B. 40® double metal bracket top fix front view

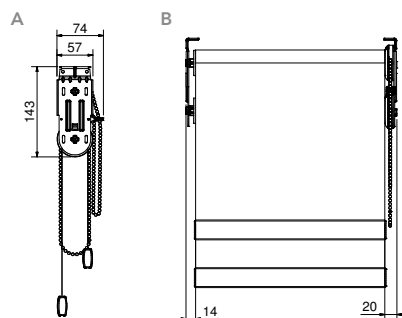

LOUVOLITE SIDE CONTROL SYSTEMS MAXIMUM BLIND SIZE

SYSTEM	FABRIC GROUP	BLIND WIDTH (m) FOR BLIND DROP (m)						MAX HOLDING WEIGHT
		0.5	1.0	1.5	2.0	2.5	3.0	
System 40®	up to 200g/m sq 200 > 320g/m sq 320 > 485g/m sq	5.0	5.0	5.0	5.0	5.0	5.0	9lb blind at 6mm deflection
		3.75	3.75	3.75	3.75	3.75	3.75	
		5.0	5.0	5.0	3.55	2.7	2.1	

For the most up-to-date information view the online pdf at www.louvolitecommercial.com/systems/

Your Louvolite System 40® Double Bracket Distributor:



CI/SIB 1976 reference by SIB Agency		
(76.7)	X	