

SYSTEM 40[®] MOTORISED ROLLER SYSTEM

LITHIUM RE-CHARGEABLE BATTERY 1200-SHORT

Max width with the 40mm tube: 2.5m
 Max width with the 40mm HD tube: 2.8m
 Max drop: up to 5m (fabric dependant)
 Max area: up to 12.5m² (fabric dependant)

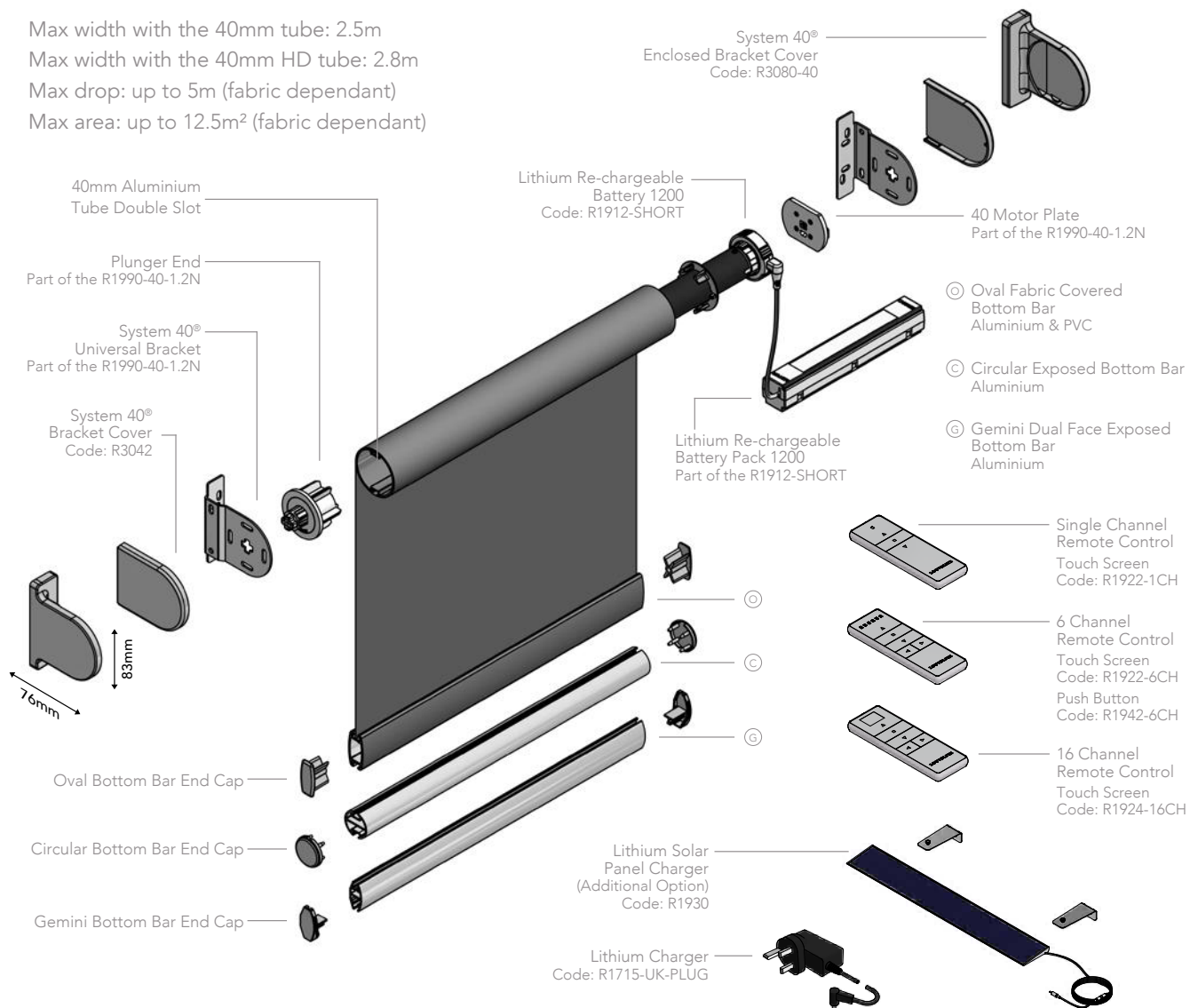

- Operate blinds effortlessly and economically with the Louvolite One Touch[®] Lithium re-chargeable 1200-SHORT Motor.
- Designed to fit smaller windows with a minimum blind width of 355mm, such as bay windows.
- Soft start and stop technology with patented helical gear for reduced noise level to 30db.
- Manufactured using high quality engineering grade polymer.
- Easy and quick installation, no wiring needed.
- Child safe by design. Set up to four limits to stop blind at your chosen height.
- Motor weight capacity of 3.5kg.
- Conveniently operate singular or multiple blinds with a One Touch remote control.
 Touch Screen Remotes:
 single channel (R1922-1CH), 6 channel (R1922-6CH) and 16 channel (R1924-16CH).
 Push Button Remotes:
 single channel wall fit (R1926), 6 channel (R1942-6CH) and 6 channel timer wall fit (R1932).
- Can be operated with the Louvolite Smart Home Hub (R1764-UK). Using wifi any One Touch blinds can be operated remotely via the app on a smart phone/tablet or by voice command with Amazon Echo, Google Home and Siri.
- Charge the Lithium motor with a 8.4v charger (4m cable) or with a solar panel charger (1.4m cable) which trickle charges the motor from daylight.
- Colours available: 35/40mm motor set: white, beige, black and anthracite grey.

HARDWARE SPECIFICATION

Motorised Roller System

Our motorised roller blinds are manufactured using the specifically designed grooved aluminium tubing. The specified fabrics are formed and held into the tube with locking tape.

The brackets are made from mild steel, zinc plated and powder coated, suitable for top, face or side fixing.

A sprung plunger end mechanism is positioned at the opposite end to the motor plate, providing a more secure fit of the blind.

Performance

To ensure a positive performance, all Louvolite components are designed and manufactured in the UK using prime quality plastic materials.

10 year life cycle testing is done to ensure long lasting performance.

Operation

Using motorised operation, all blinds must be compliant with the child safety elements of BS EN13120.

Bottom Bar

Oval, made of aluminium or pvc, can be single or double wrapped in fabric or left exposed, while circular and the dual face Gemini, made of aluminium, only have the fabric formed and locked into the top part to leave the bar exposed. All fabric is formed and held into place with locking tape. The dual face Gemini bar, smooth on one side and angular on the other, improves the ease of manufacture and use of thicker laminate fabrics.

Maintenance

All of the roller blind system components are manufactured using aluminium, treated steel and plastic. They do not present any corrosion problems in normal environments. The system has been designed for a smooth operation, together with a rigidity to prolong the window blind's working life. Manufacturing size restrictions are included in this specification brochure.

ADDITIONAL OPTIONS - CASSETTES

System 32/40® Open Cassette
- 40mm fascia depth. Code: RM2106
white, beige, black, satin, chrome, bronze & anthracite grey



Bracket Covers: RM2137
white, beige, black, satin, chrome, bronze, grey & anthracite grey

System 32/40® Full Fascia Cassette
- 70mm fascia depth. Code: RM2108
white, black & anthracite grey



Bracket Covers: RM2139
white, black & anthracite grey

System 32/40® Hybrid Closed Cassette.
Fixing extrusion code: R3360
Curved profile code: R3362
white, black & anthracite grey

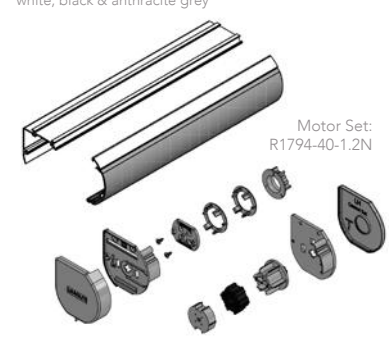

MAX BLIND SIZE

LITHIUM 1200-SHORT

	FABRIC GROUP	BLIND WIDTH (m) FOR BLIND DROP (m) (Max deflection 6mm)						40HD TUBE	PARAMETERS		FEATURES		
		0.5	1.0	1.5	2.0	2.5	3.0		Rated Torque	1.2Nm	Min Blind Width	355mm	
35°	up to 200g/m sq 200 > 320g/m sq 320 > 485g/m sq	3.0	3.0	3.0	2.0			Rated RPM	25rpm	Motor Diameter	25mm	Motor Weight Capacity	3.5kgs
		2.0	2.0	2.0	2.0								
		2.0	2.0	2.0	1.5								
40°		5.0	5.0	5.0	5.0	5.0	5.0	Rated Voltage	DC7.4V	Rated Power	6.7W	Rated Current	900mA
		4.0	4.0	4.0	4.0	4.0	3.75						
		5.0	5.0	5.0	3.5	2.7	2.1						
								IP Class	IP44	Inbuilt Receiver	Yes	Power Source	Re-chargeable External Battery Pack (plug-in charger or solar panel)

For the most up-to-date information view the online pdf at www.louvolitecommercial.com/systems/

Your Louvolite Lithium Motorised Roller System Distributor:



CI/SIB 1976 reference by SIB Agency

(76.7) X